

June 15, 1954

S. G. LIPIC ET AL

2,680,962

CIGARETTE LIGHTER

Filed Oct. 12, 1949

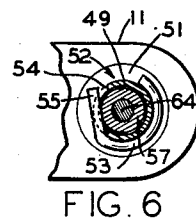
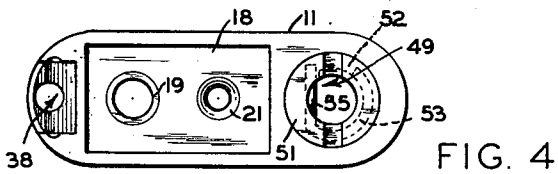
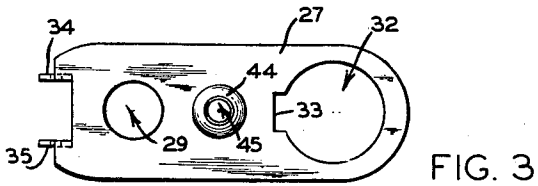
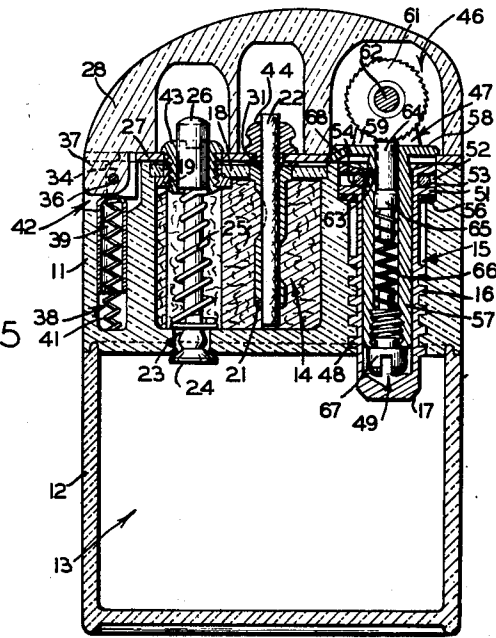
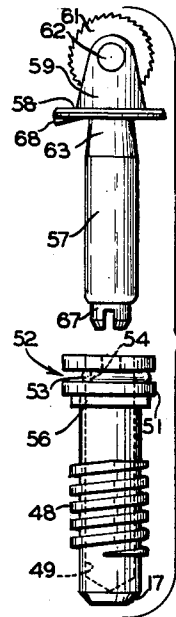
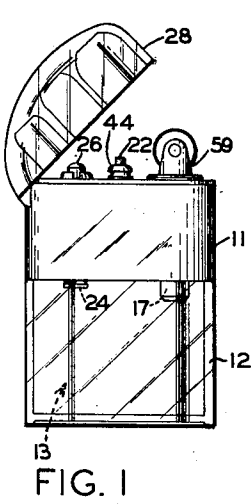

INVENTORS
SYLVESTER G. LIPIC
FARNHAM F. BOYLE
LUTHER S. LYON

BY *John H. ...*
ATTORNEY

UNITED STATES PATENT OFFICE

2,680,962

CIGARETTE LIGHTER

Sylvester G. Lipic, Sappington, Farnham F. Boyle, St. Louis, and Luther S. Lyon, Webster Groves, Mo., assignors, by mesne assignments, to Ritepoint, Inc., St. Louis, Mo., a corporation of Missouri

Application October 12, 1949, Serial No. 121,016

3 Claims. (Cl. 67-7.1)

1

This invention relates to pyrophoric lighters, commonly referred to as cigarette lighters. The improvements which constitute the invention comprise features which make the lighter more convenient to use and more durable in service, while adding to facility in manufacture.

The summary about to follow includes the salient features of the invention and will assist in understanding the invention and the preferred embodiment specifically illustrated in the accompanying drawings and later described in detail. It may be understood, however, that the invention is defined in the accompanying claims, and the inclusion in this summary of some particular element or arrangement does not necessarily limit the invention since part of the invention may be practiced to advantage without using the whole.

The lighter has a casing body which forms a fuel chamber from which projects a wick. A face plate is secured over and to the top of the body and has ears to which is hinged a cap covering the plate, a pin passing through the ears and a lug or boss projecting from the cap to form the hinge connection. The lug and the ears are enclosed in a recess in the top of the casing body to conceal the hinge. A well is formed in the body below the recess to house a spring and spring sleeve, bearing against the lug to releasably hold the cap in open or closed position.

The invention is directed particularly, but not exclusively, to a lighter of the visible fuel supply type in which an auxiliary reservoir communicates with the aforesaid fuel chamber. A transfer valve has a stem which projects through the top of the casing body and controls flow of fuel from the reservoir to the chamber. The reservoir is filled through a bore formed through the casing body, which is stopped by a fitting or spark wheel adapter threaded in the bore.

The face plate (to which the cap is hinged and which covers the top of the casing body) is secured to the body preferably by a screw in the form of a threaded bushing which fits about the valve stem.

The face plate has an opening or hole which registers with the top of the bore in the casing body (which, as previously explained, holds the spark wheel adapter). A key notch in the hole receives a key on the spark wheel holder so the spark wheel is properly positioned with respect to the wick.

The spark wheel adapter has a socket to receive the shank of the spark wheel holder. The shank is tapered and a spring clip, or detent, is posi-

2

tioned in the socket to engage the smallest diameter of the shank when the spark wheel holder is in operative position, thus releasably securing the holder in proper position.

A wick holder is secured to the face plate. A wick tube may be employed, in which case it is secured at its top end to the top of the casing body and in position to register with the opening in the wick holder secured on the face plate.

In the drawings, Fig. 1 is a side elevational view of a cigarette lighter embodying the improved lighter mechanism of the instant invention;

Fig. 2 is a vertical sectional view of the lighter showing the parts thereof in their assembled relationship;

Fig. 3 is a top view of a hinge plate employed as a part of the lighter mechanism assembly;

Fig. 4 is a top view of a lighter mechanism body showing therein a valve stem bushing, a wick tube and a spark wheel holder adapter employed in the lighter mechanism;

Fig. 5 is an exploded view showing side elevation of the spark wheel holder and spark wheel adapter; and

Fig. 6 is a cross sectional view showing in particular the clip for securing the spark wheel holder in position.

The improved lighter mechanism of the instant invention includes a lighter mechanism body 11 (Fig. 2) which may be of any suitable material, such as a plastic or metal. This body is supported on a transparent fluid reservoir housing 12 to which the same is sealed as a closure for a fluid reservoir 13. Within the body 11 there is provided a fluid well 14 which is filled with an absorbent material such as cotton. Also within the body 11 is a cylindrical compartment 15 which is open at the top of the body and extends into the fluid reservoir 13. This compartment is threaded internally at 16 to receive a spark wheel holder adapter 17, later to be described. The well 14 of the body is closed at its top by means of an insert 18 (Fig. 4) which is sealed to the body. This insert has an internally threaded valve stem bushing 19 secured thereto and also supports a perforated wick tube 21 which is sealed in an opening in the insert. The perforated wick tube 21 extends approximately to the bottom of the well 14 for the purpose of retaining an end of a wick 22 at the bottom of the well. Fluid from the reservoir 13 is admitted to the fluid well 14 through an opening 23 in the bottom of the body 11, which opening is normally closed by a valve 24, the latter being held in its closed position by means of a coil spring 25. The valve is operated by means

of a valve stem plunger 26 which extends a suitable distance above the insert 18.

A hinge plate 27 serves as a means for connecting a lighter mechanism cap 28 to the lighter mechanism body 11. This plate, which is shown in Fig. 3, is preferably made of metal and has openings 29, 31 and 32 drilled therein. At the periphery of the opening 32 there is a key notch 33 whose purpose will be explained later. Also forming a part of the plate 27 are two ears 34 and 35 to which the cap 28 is hinged by means of a hinge pin 36 passed therethrough and through a boss 37 formed as a part of the cap. Within a compartment 38 in the body 11 there is housed a plunger 39 which is urged by means of a coil spring 41 against the boss 37 of the cap to hold the same in either its open or closed position. Here, the boss 37 of the cap 28 together with the ears 34 and 35 of the hinge plate 27 are enclosed in a recess 42 within the body 11 to conceal the hinge.

The hinge plate 27 together with the cap 28 which is hinged thereto is secured to the body 11 by means of a valve stem bushing nut 43 which is threaded into the valve stem bushing 19, this expedient providing a simple means for attaching the lighter cap.

Also secured to the hinge plate 27 in the opening 31 therein is a wick holder 44. This holder has an internal bore 45 therein which is slightly smaller than the internal diameter of the wick tube 21. Here also, a novel structure is provided which insures a positive holding of the lighter wick 22 at the same time allowing the same to be quickly and easily threaded in the lighter. Thus, after the cap 28 is hinged to the plate 27, the wick 22 is threaded into the holder 44 from the top thereof, the holding portion of the complete wick retainer extending only over a small portion of the wick equivalent to the length of the bore of the holder. Inasmuch as the internal diameter of the wick tube 21 is sufficiently large to have the wick 22 pass therein the wick is easily threaded into the tube when the hinge plate is placed in position in the top of the body 11.

Also forming an unique part of the improved lighter mechanism is a spark wheel assembly 46 which includes the spark wheel holder adapter 47, previously mentioned, and a spark wheel holder 47. The former element includes an externally threaded shaft 48 into which there is drilled a bore 49 extending substantially into an end of the shaft. As a part of the adapter 47 there is a flange 51 which forms a head on the shaft 48. This flange has a groove or recess 52 channelled therein which provides a retainer for a clip spring 53. The internal wall of the groove 52 has a cut-out portion 54 thereof which opens into the bore 49 of the shaft for a measured distance to permit an arm 55 of the clip spring 53 to extend into the bore 49 as shown in Figs. 4 and 6. The entire adapter is threaded into the compartment 15 and is sealed therein by means of a gasket 56 which is clamped between the flange 51 and a shouldered portion of the compartment.

The spark wheel holder 47 comprises a hollow shank 57 which has a shoulder 58 thereon providing a head therefor overlying the hinge plate 27. Arising from the shoulder 58 are two uprights 59 between which a spark wheel 61 is rotatable on a shaft 62. The shank 57 of the holder has a reduced section 63 thereon which flares downwardly from the shoulder 58 against which the arm 55 of the clip spring 53 operates to hold the spark wheel holder in the adapter, the said

arm being cammed outwardly by the reduced section when the spark wheel holder is removed. A flint piece 64 is urged against the wheel 61 by means of a plunger 65 and a spring 66 housed within the shank 57. Also, a spring retainer nut 67 is threaded into an end of the shank.

The above described spark wheel assembly provides a means for securing the spark wheel in the lighter and overcomes a problem long present in the art. Thus, as is well known, the spark wheel must be aligned with the wick of the lighter in order that the spark produced by the wheel is projected toward the wick. In prior art practices it has been the custom to thread the spark wheel holder into the body which requires that the length and pitch of the threads be accurately determined so that the spark wheel holder when threaded tightly into the body comes to rest therein in aligned position with the wick. This, of course, is a difficult manufacturing procedure and is a costly one. As held in the lighter by means of the spark wheel holder adapter, above described, the spark wheel holder of the instant invention is free to rotate therein and after the adapter has been secured tightly in the body can be easily rotated to aligned position with the wick.

From the foregoing it is obvious that means must be provided to hold the spark wheel holder against rotation in the adapter once the former is aligned with the wick of the lighter. For this purpose a key 68 is struck downwardly from the shoulder 58 of the holder. This key engages in the key notch 33 in the hinge plate 27 and provides for the accurate registry of the spark wheel holder in alignment with the wick 22 of the lighter.

Various changes may be made in the details of construction, within the scope of the appended claims, without departing from the spirit of this invention. Parts of the invention may be used without the whole and improvements may be added while retaining some or all of the advantages of the invention.

What is claimed is:

1. In a cigarette lighter having a lighter mechanism including a lighter mechanism body providing a cylindrically internally threaded compartment therein, a spark wheel assembly comprising a spark wheel holder adapter taking the form of an externally threaded shaft adapted to be screwed into said compartment and having a longitudinal bore therein extending substantially to an end thereof, a flange on said shaft forming a head therefor at the bore end thereof, an annular recess in said flange having a portion thereof cut into said bore, a clip spring adapted to be pressed into said recess and having an arm thereof urged into said bore, a spark wheel holder taking the form of a shank adapted to be passed into the bore of said adapter, a shoulder on said shank providing a head therefor, a pair of uprights rising from the head of said shank, and a reduced section formed externally of said shank flaring downwardly from the shoulder thereof into which the said arm of said clip spring is urged to releasably retain said spark wheel holder in said adapter.

2. A spark wheel holder and adapter therefor comprising a sub-assembly for a lighter having a body portion, said adapter comprising an elongated substantially hollow plug having opposed open and closed ends, said plug having a slot extending transversely through a wall thereof and in open communication with the interior of said plug, a spark wheel holder having an elongated

5

shank slidably disposed within said adapter, means carried on said adapter extending through said slot and engaging against said shank to resist frictionally relative sliding movement between said shank and said adapter, and means externally of the adapter for releasably securing said adapter within said body portion.

3. In a lighter, a casing body forming a fuel chamber and having a socket open at the top of the body, said body having a notch extending inwardly from the top and positioned adjacent said socket, a spark wheel holder having a shank with a tapered section seated in the socket and a flange to engage the top of the body around the socket, said socket having a recess formed in its wall communicating with the interior of the socket, a resilient grasping means having a portion thereof disposed in said recess and having another portion thereof extending into said socket and constructed and arranged to engage the tapered section and thereby releasably hold the spark wheel holder in position with the flange engaging the top of the body, and a key extending downwardly from the flange constructed and arranged to engage in the notch at the top of the body to position the spark wheel holder.

6

References Cited in the file of this patent

UNITED STATES PATENTS

Number	Name	Date
1,986,098	Beck -----	Jan. 1, 1935
2,211,500	Gabritsch -----	Aug. 13, 1940
2,242,906	Evans -----	May 20, 1941
2,485,956	Campos -----	Oct. 25, 1949
2,493,081	Negbaur -----	Jan. 3, 1950
2,497,137	Rodanet -----	Feb. 14, 1950
2,529,094	Miller -----	Nov. 7, 1950

FOREIGN PATENTS

Number	Country	Date
503,699	France -----	June 16, 1920
100,850	Austria -----	Aug. 25, 1925
274,045	Britain -----	Oct. 13, 1927
336,748	Britain -----	Oct. 23, 1930
486,178	Britain -----	May 31, 1938
878,318	France -----	Jan. 18, 1943
566,710	Britain -----	Jan. 10, 1945
568,848	Britain -----	Apr. 23, 1945
593,146	Britain -----	Oct. 9, 1947